

- NOTES:
SPECIFICATION:
- CURRENT RATING: 3.0 A
 - VOLTAGE RATING: 3.0 V
 - VBUS & GND PINS AND OTHER PINS: 40mΩ/PIN MAX SHIELD: 50mΩ/MAX LLCR MAX. CHANGE OF ALL PINS: 10Ωm
 - INSULATION RESISTANCE: 100MΩ MIN
 - DIELECTRIC WITHSTAND VOLTAGE, AC 100V FOR 1MINUTE
 - INSERTION FORCE: 0.5~2.0kgf
 - UNMATING FORCE: 0.8~2.0kgf
 - DURABILITY: 10000 CYCLES
 - OPERATING TEMPERATURE: -35°C~+85°C
 - THE PEAK TEMPERATURE ON THE BOARD SHALL BE MAINTAINED FOR 10 SECONDS AT 210-230°C
 - WATERPROOF: IP-X7.

USB TYPE C PIN ASSIGNMENTS

PIN NUMBER	SIGNAL NAME	PIN NUMBER	SIGNAL NAME
A1	GND	B12	GND
A4	VBUS	B9	VBUS
A5	CC1	B8	SBU2
A6	DP1	B7	DN2
A7	DN1	B6	DP2
A8	SBU1	B5	CC2
A9	VBUS	B4	VBUS
A12	GND	B1	GND

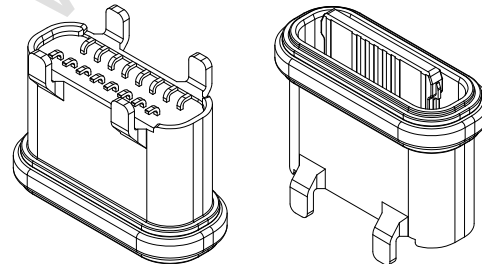
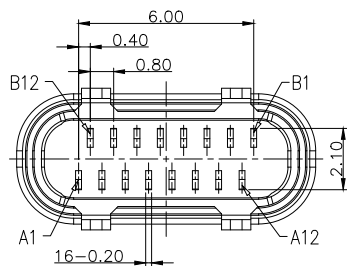
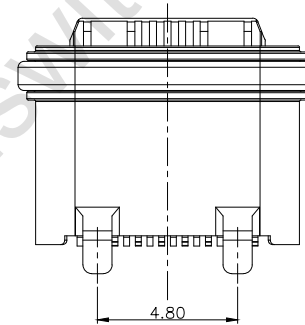
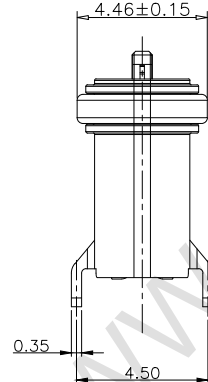
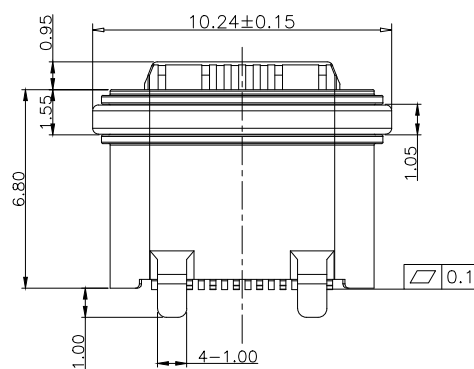

TABLE:

NO	PART	Q'TY	Material
1	SHELL	1	ZINC ALLOG, NI30u"Min PLATED
2	CONTACT	16	C7025, TIN80u"/Au3u"/NI30u"PLATED
3	MID PLATE	1	SUS301, NO PLATING
4	HOUSING	1	LCP(E130i) UL94 V-0 BLACK
5	CAP	1	LCP UL94 V-0 BLACK
6	WATERPROOF RING	1	SILICONE(SI/60-65A) UL94 V-0 RED



DESIGN	MISS ZENG	SC ALL			TOLERANCE	ANGLES	品名: TYPE-C连接器 型号: TYPE-C 16P 防水母座立式贴板 H=6.8mm
DRAWIGN	MISS LI	ANIT	mm				
CHECK	Mr. ZENG	SIZE	A4 : 210*297				
APPROVAL		VERSION	01				



东莞市航宏电子科技有限公司
Dongguan Hanghong Electronics Co., Ltd.

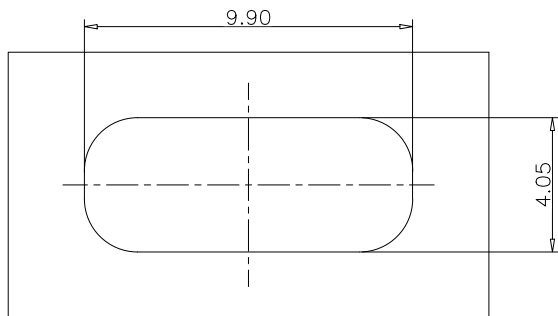

密封开孔参考尺寸(只供参考)
 组装外壳时需要打环保润滑油

机壳面板对密封圈与缩量0.20Min
 (建议压缩量为密封圈下压方向30-40%)

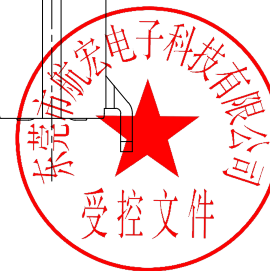
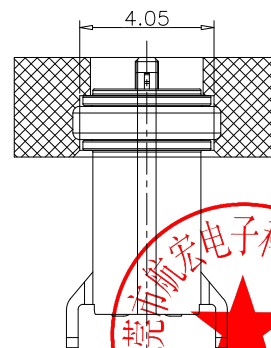
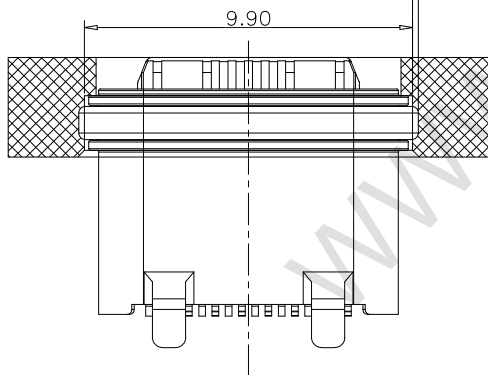

DESIGN	MISS ZENG	SC ALL			TOLERANCE	ANGLES
DRAWIGN	MISS LI	ANIT	mm			
CHECK	Mr. ZENG	SIZE	A4 : 210*297			
APPROVAL		VERSION	01			

品名：TYPE-C连接器
 型号：TYPE-C 16P 防水母座立式贴板
 H=6.8mm



东莞市航宏电子科技有限公司
 Dongguan Hanghong Electronics Co., Ltd.