

INTERFACE(FRONT VIEW)

A1	A2	A3	A4	A5	A6	A7	A8	A9	A10	A11	A12
GND			VBUS	CC1	DP1	DN1	SBU1	VBUS			GND
GND			VBUS	SBU2	DN2	DP2	CC2	VBUS			GND
B12	B11	B10	B9	B8	B7	B6	B5	B4	B3	B2	B1

PIN ASSIGNMENT

PIN NO.	A1&B12	A4&B9	B8	A5	B7	A6	A7	B6	A8	B5	A9&B4	A12&B1
SIGNAL NAME	GND	VBUS	SBU2	CC1	DN2	DP1	DN1	DP2	SBU1	CC2	VBUS	GND
PCB PAD NO.	C1	C2	C3	C4	C5	C6	C7	C8	C9	C10	C11	C12

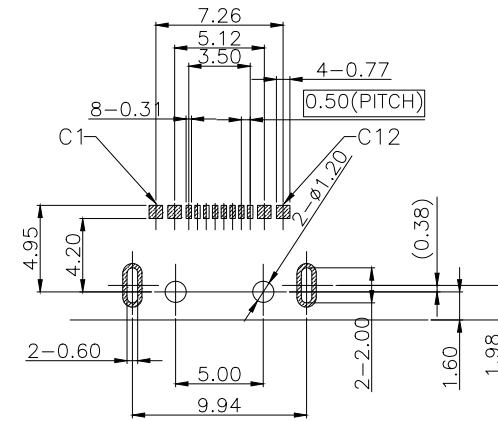

RECOMMENDED PCB LAYOUT(TOP VIEW)

THICKNESS T=1.0mm
DEFAULT TOLERANCE+/-0.05

NOTES:

- MATERIAL: SEE "TABLE 1";
- FINISH: SEE "TABLE 1";
- ELECTRICAL :
 - CONTACT CURRENT RATING :
5A(VBUS PIN 1.5A/PIN),
5A(GND PIN 1.25A/PIN MAX),0.25A/PIN(OTHER PIN).
 - INSULATION RESISTANCE :
100 MEGAOHMS MIN. AT 250VDC.
 - DIELECTRIC WITHSTANDING VOLTAGE :
100VAC MIN.
 - LOW LEVEL CONTACT RESISTANCE :
INITIAL 40mΩ MAX.
AFTER 50mΩ MAX.
- MECHANICAL CHARACTERISTICS :
 - MATING FORCE: 5~20N.
 - UNMATING FORCE: 8~20N(INITIAL),6~20N(AFTER 5000 CYCLES);
 - DURABILITY : 5,000 MATING CYCLES.
 - OPERATING TEMPERATURE : -40°C TO +80°C

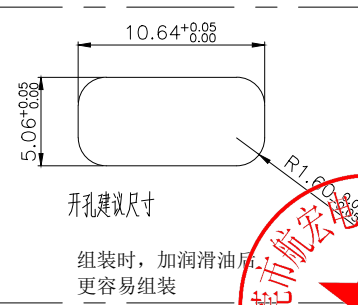
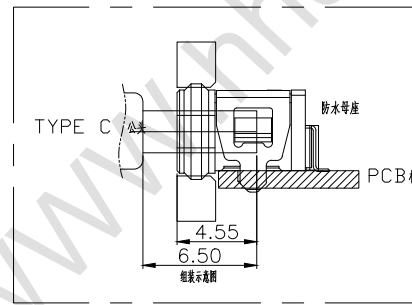
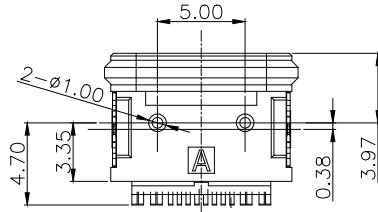
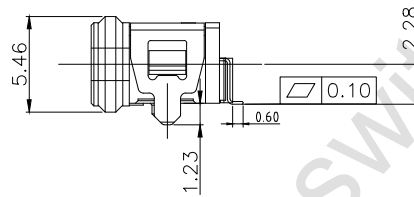
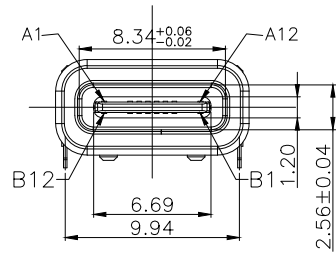

TABLE 1:

NO.	PART NAME	QTY	MATERIAL	DESCRIPTION	REMARK
⑥	Shell-2	1	Stainless steel	NI PLATING;	T=0.20mm
⑤	Shell-1	1	Stainless steel	NI PLATING;	T=0.25mm
④	MID PLATE	1	Stainless steel		T=0.15mm
③	Terminal-B	8	铜镍硅合金	Au:3u" PLATING;	T=0.15mm
②	Terminal-A	8	铜镍硅合金	Au:3u" PLATING;	T=0.15mm
①	Housing	1	HIGH TEMP	Black	

DESIGN	MISS ZENG	SC ALL			TOLERANCE	ANGLES	品名: TYPE-C 型号: TYPE-C 16P 卧贴插板
DRAWING	MISS LI	ANIT	mm		.X ±0.50	.X ±2	
CHECK	Mr. ZENG	SIZE	A4 : 210*297		.X ±0.30	.X ±1	
APPROVAL		VERSION	01		.XX ±0.10	.XX ±0.5	
					.XXX ±0.05		



东莞市航宏电子科技有限公司
Dongguan Hanghong Electronics Co., Ltd.