

NOTES:

SPECIFICATION:

1. CURRENT RATING: 3.0A MAX
2. DIELECTRIC WITHSTAND VOLTAGE: 100VAC
3. TEMPERATURE RANGE: -30 °C ~ 85 °C
4. CONTACT RESISTANCE: 40 MILLIONHM MAX
5. INSULATION RESISTANCE: 100 MEGOHMS MIN.
6. INSERTION FORCE : 5N~20N
7. UNMATING FORCE: 8N~20N
8. DURABILITY:10,000 CYCLES



3	Shell		PA9T (G.F30%)	
2	Contact	5	Phosphor bronze_C5191R-EH Au/Ni Plating T=0.12mm	
1	Housing	1	LCP (G.F30%)	
ITEMPART		NAMQ'TY		FINISH
				NOTE

DESIGN	MISS ZENG	SC ALL			TOLERANCE	ANGLES
DRAWIGN	MISS LI	ANI T	mm		X. $\pm 0.50$	X. $\pm 2$
CHECK	Mr. ZENG	SIZE	A4 : 210*297	.X $\pm 0.30$	.X $\pm 1$	
APPROVAL		VERSION	01	.XX $\pm 0.10$	.XX $\pm 0.5$	
				.XXX $\pm 0.05$		

品名: TYPE-C  
型号: TYPE-C 16P 沉板1.65



**东莞市航宏电子科技有限公司**  
Dongguan Hanghong Electronics Co., Ltd.

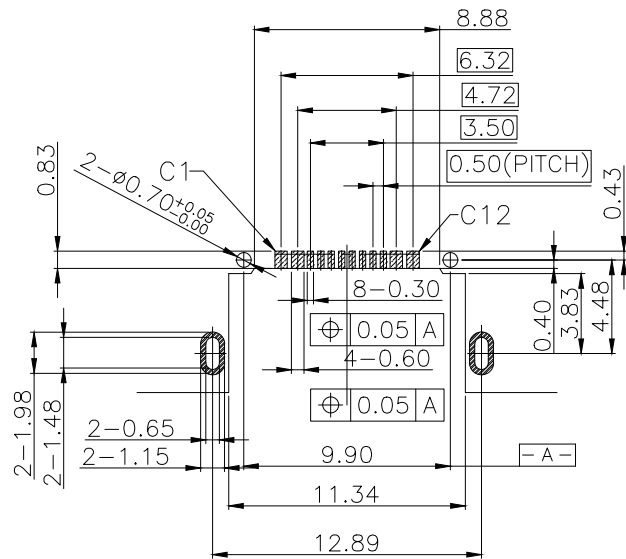

加工时确保加工到位, 未到位时会影响端子落板  
RECOMMENDED PCB LAYOUT(TOP VIEW)

THICKNESS T=1.0mm  
 DEFAULT TOLERANCE+/-0.05

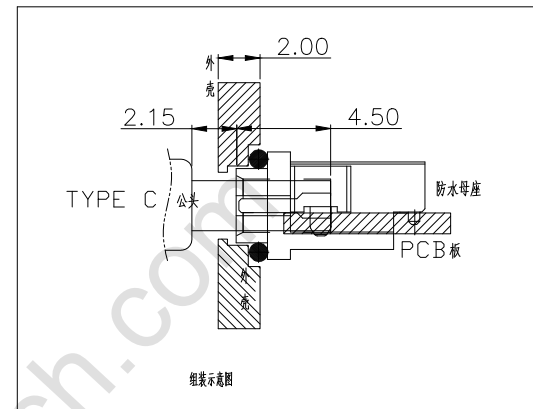

INTERFACE(FRONT VIEW)

A1	A2	A3	A4	A5	A6	A7	A8	A9	A10	A11	A12
GND			VBUS	CC1	DP1	DN1	SBU1	VBUS			GND
GND			VBUS	SBU2	DN2	DP2	CC2	VBUS			GND
B12	B11	B10	B9	B8	B7	B6	B5	B4	B3	B2	B1

PIN ASSIGNMENT

PIN NO.	A1&B12	A4&B9	B8	A5	B7	A6	A7	B6	A8	B5	A9&B4	A12&B1
SINGAL NAME	GND	VBUS	SBU2	CC1	DN2	DP1	DN1	DP2	SBU1	CC2	VBUS	GND
PCB PAD NO.	C1	C2	C3	C4	C5	C6	C7	C8	C9	C10	C11	C12

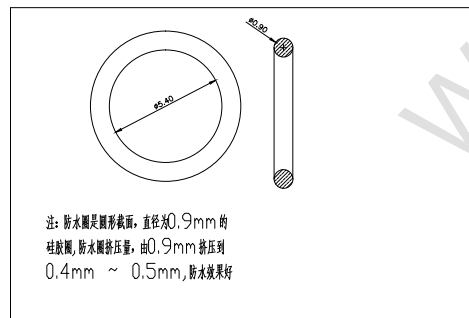

DESIGN	MISS ZENG	SC ALL		
DRAWIGN	MISS LI	ANI T	mm	
CHECK	Mr. ZENG	SIZE	A4 : 210*297	
APPROVAL		VERSION	01	

TOLERANCE	ANGLES
X. ±0.50	X. ±2
.X ±0.30	.X ±1
.XX ±0.10	.XX ±0.5
.XXX ±0.05	

品名: TYPE-C  
 型号: TYPE-C 16P 沉板1.65



**东莞市航宏电子科技有限公司**  
 Dongguan Hanghong Electronics Co., Ltd.