

NOTE:

- 1.MATERIAL SPECIFICATION:
 - 1.HOUSING:HIGH TEMPERATURE RESISTANT PLASTIC(LCP),UL94 V-0.
 - 2.CONTACTS:COPPER ALLOY(C1814)T=0.12mm
 - 3.MID PLATE: STAINLESS STEEL(SUS301)T=0.15mm
 - 4.SHELL: STAINLESS STEEL(SUS304)T=0.30mm
- 2.PLATING SPECIFICATION:
 - 2-1.CONTACTS:
 - Ni 50u" MIN. UNDER PLATED OVER ALL.
 - Au PLATED ON THE FUNCTIONAL AREA OF CONTACT.
 - (GOLD PLATING THICKNESS FOLLOW THE P/N)
 - PLATING SPECIFICATIONS OF THE SOLDER AREA FOLLOW THE P/N
 - 2-2.FRONT SHELL:
 - Ni 30u" MIN. UNDER PLATED OVER ALL.
 - 2-3.MID PLATE:
 - CLEAR ONLY
- 3.MECHANICAL PERFORMANCE,
 - 3-1.INSERTION FORCE: 0.5~2.0kgf.
 - 3-2.EXTRACTION FORCE: 0.8kgf~2.0kgf.
 - 3-3.DURABILITY: 10000 CYCLES.
- 4.ELECTRICAL PERFORMANCE,
 - 4-1. CURRENT RATING:5.0A
VOLTAGE RATING:5.0V
 - 4-2. LLCR:
 - VBUS & GND PINS AND OTHER PINS: 40mΩ/PIN MAX.
 - SHIELD: 50mΩ/MAX.
 - LLCR MAX. CHANGE OF ALL PINS: 10mΩ.
 - 4-3.INSULATION RESISTANCE: 100MΩ MIN
 - 4-4.DIELECTRIC WITHSTAND VOLTAGE,AC 100V FOR 1 MINUTE.
5. ENVIRONMENTAL PERFORMANCE:
 - OPERATING TEMPERATURE: -25°C~+85°C.
 - REFLOW:
 - THE PEAK TEMPERATURE ON THE BOARD SHALL
 - BE MAINTAINED FOR 10 SECONDS AT 260°C.

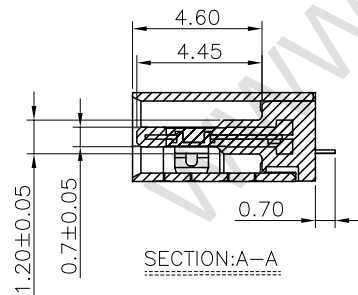
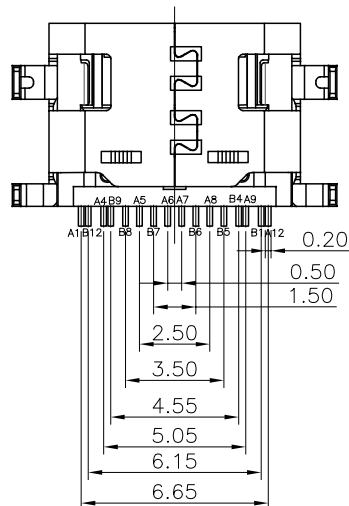
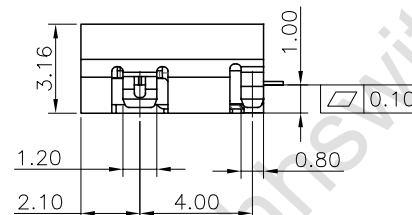
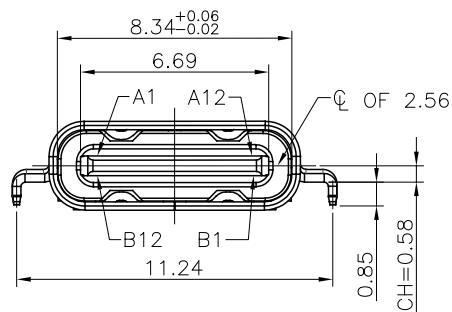

DESIGN	MISS ZENG	SC ALL			TOLERANCE	ANGLES	品名: TYPE-C
DRAWIGN	MISS LI	ANIT	mm		X.X ± 0.30	X° ± 5°	
CHECK	Mr. ZENG	SIZE	A4 : 210*297		X.XX ± 0.20	X.X ± 2°	
APPROVAL		VERSION	01		X.XXX ± 0.10		

品名: TYPE-C
 型号: TYPE-C 16P 无弹 沉板1.0



东莞市航宏电子科技有限公司
 Dongguan Hanghong Electronics Co., Ltd.

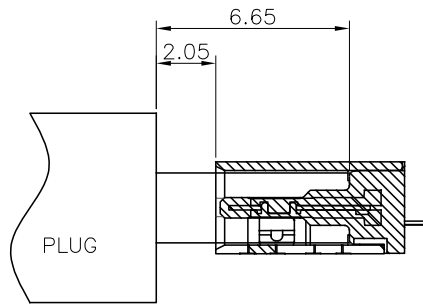

AFTER MATING

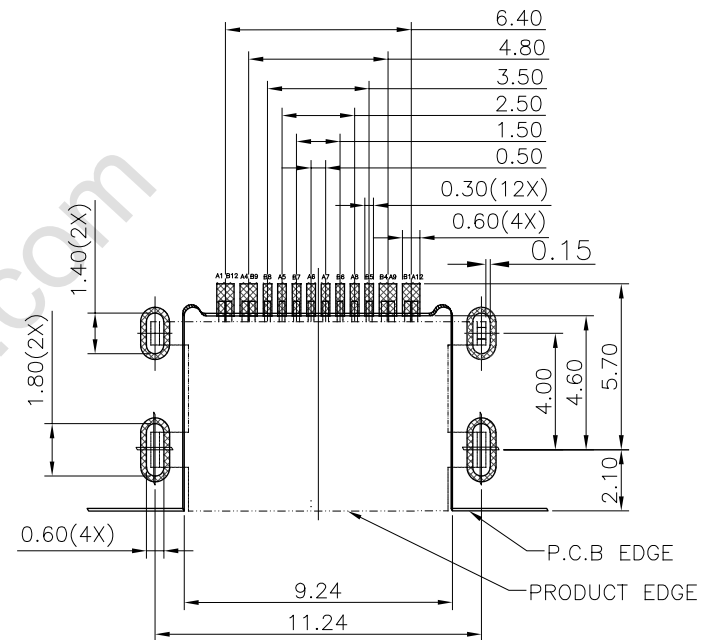

RECOMMENDED PCB LAYOUT(TOP VIEW)
THICKNESS 0.80MM;DEFAULT TOLERANCE:±0.05

USB TYPE-C PIN ASSIGNMENTS

PIN NUMBER	SIGNAL NAME	PIN NUMBER	SIGNAL NAME
A1	GND	B12	GND
A4	VBUS	B9	VBUS
A5	CC1	B8	SBU2
A6	Dp1	B7	Dn2
A7	Dn1	B6	Dp2
A8	SBU1	B5	CC2
A9	VBUS	B4	VBUS
A12	GND	B1	GND



DESIGN	MISS ZENG	SC ALL		TOLERANCE	ANGLES
DRAWING	MISS LI	ANIT		X.X ±0.30	X° ±5°
CHECK	Mr. ZENG	SIZE	A4 : 210*297	X.XX ±0.20	X.X ±2°
APPROVAL		VERSION	01	X.XXX ±0.10	

品名: TYPE-C
 型号: TYPE-C 16P 无弹 沉板1.0

东莞市航宏电子科技有限公司
 Dongguan Hanghong Electronics Co., Ltd.