

F E D C B A

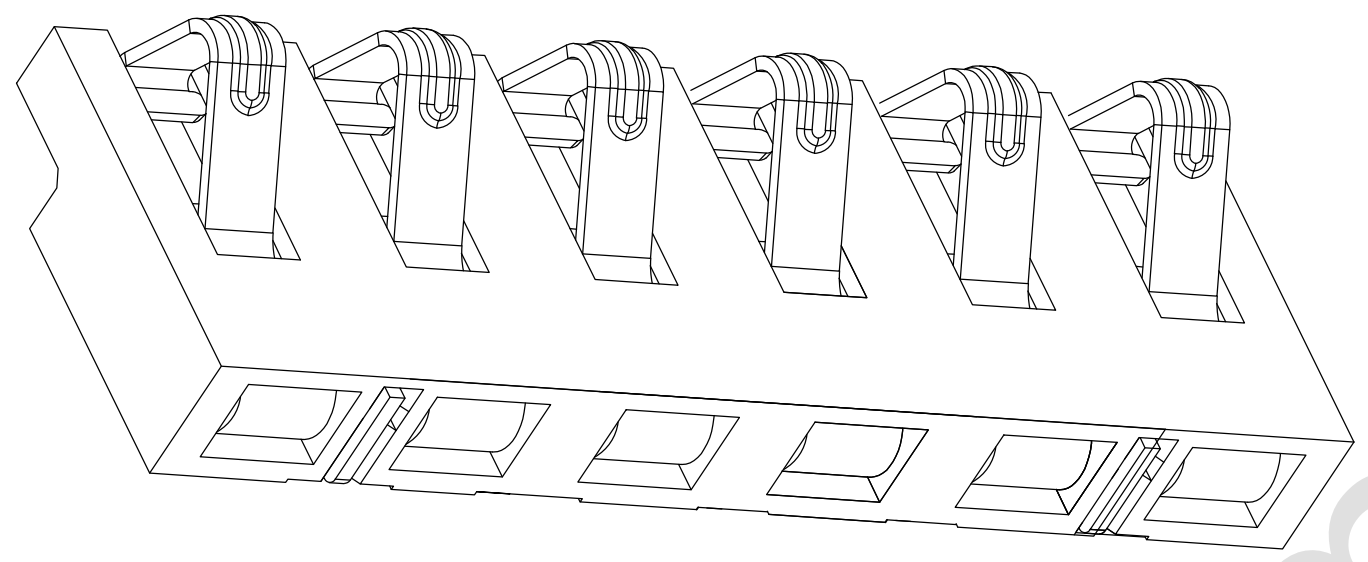

性能:
 额定电流: 2.0A
 额定电压: 12V
 耐电压: 500V
 接触电阻: 30mΩ 以内
 绝缘电阻: 500MΩ
 工作温度: -40℃~+85℃
 塑件(材质): LCP
 接触点(材质): 磷铜, 触点镀金3U"

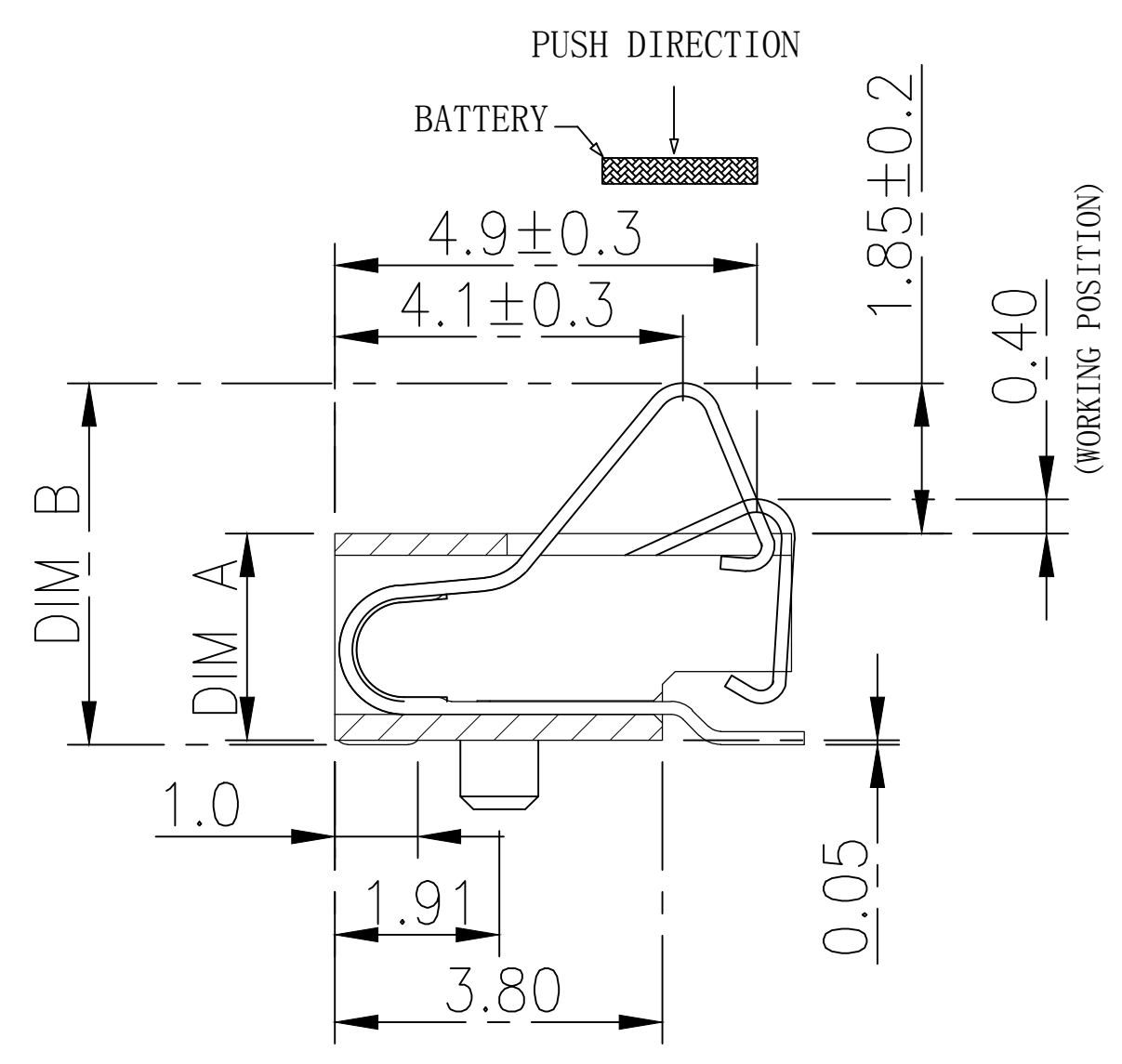
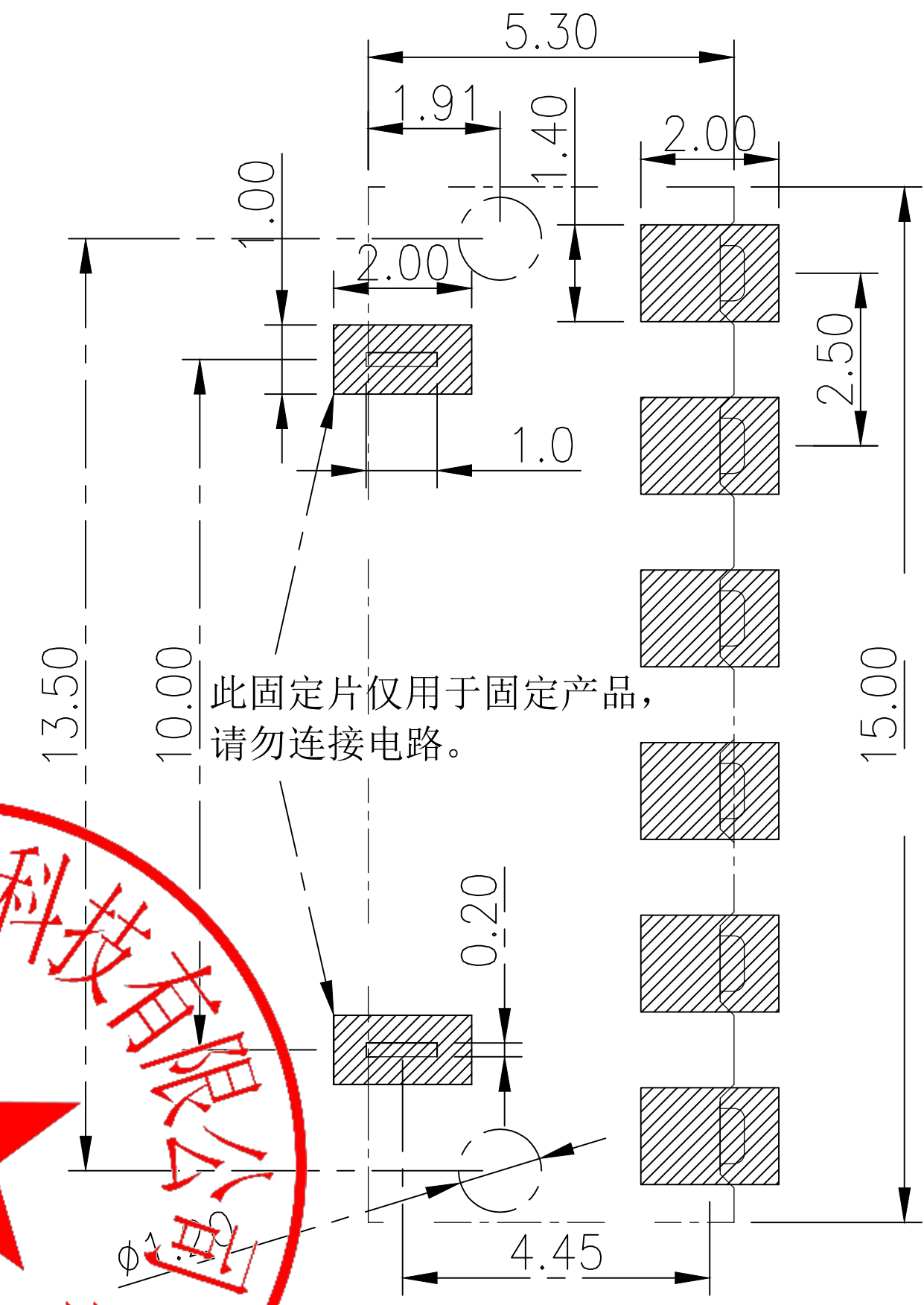
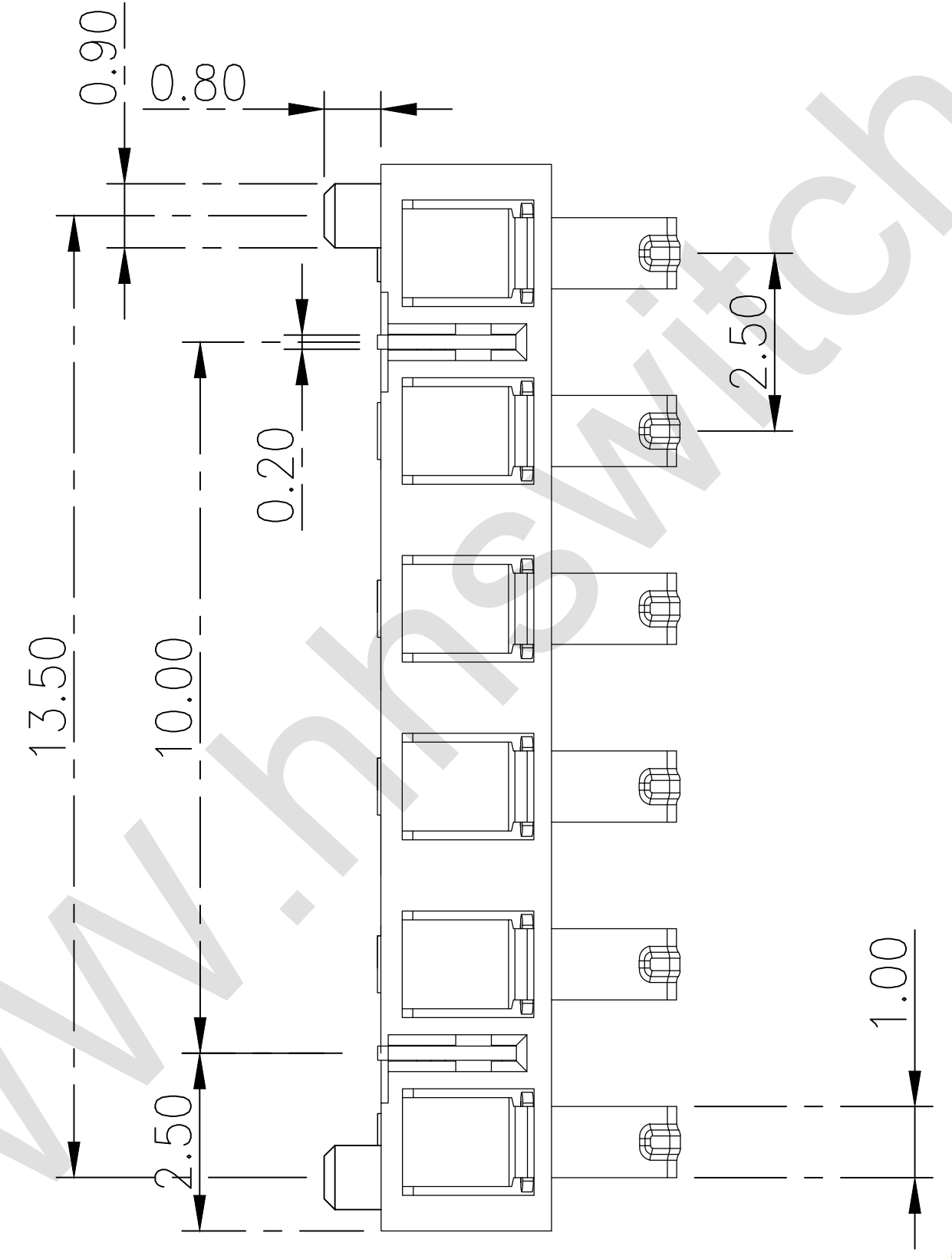
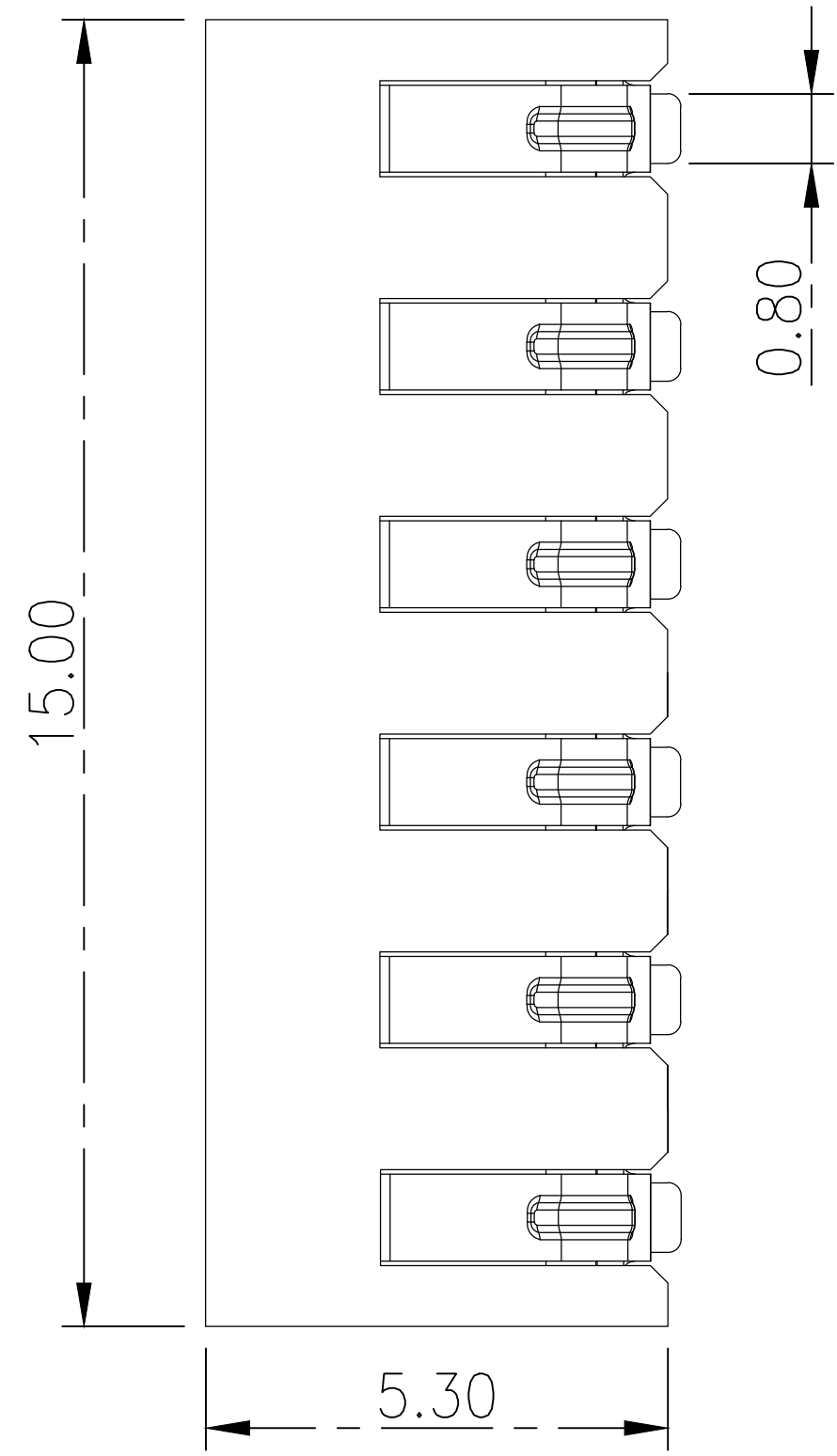

| PART NO. | DIM A | DIM B |
|---------------|-------|----------|
| BHC035-6PD240 | 2.4 | 4.30±0.2 |
| BHC035-6PD300 | 3.0 | 4.90±0.2 |
| BHC035-6PD350 | 3.5 | 5.40±0.2 |



RECOMMENDED PCB LAYOUT
TOP VIEW (. XX±0.05)

| | | | | | | |
|----------|-----------|---------|--|----------------|------------|--------------|
| DESIGN | MISS ZENG | SC ALL | | 未注公差 TOLERANCE | | |
| DRAWIGN | MISS LI | ANIT | | MM | X. ±0.35 | X.XX ±0.15 |
| CHECK | Mr. ZENG | SIZE | | A4: 210*297 | X. X ±0.25 | X. XXX ±0.05 |
| APPROVAL | | VERSION | | 01 | | |

品名: 电池连接器
 型号: BHC035-6PD300

东莞市航宏电子科技有限公司
 Dongguan Hanghong Electronics Co., Ltd.

F E D C B A