

F E D C B A

性能:

额定电流: 3.0A

额定电压: 24V

耐电压: 500V

接触电阻: 30mΩ MAX

绝缘电阻: 500MΩ

工作温度: -40℃ ~ +85℃

塑件(材质): LCP, 耐高温260℃

接触点(材质): 铜合金, 触点镀金3U

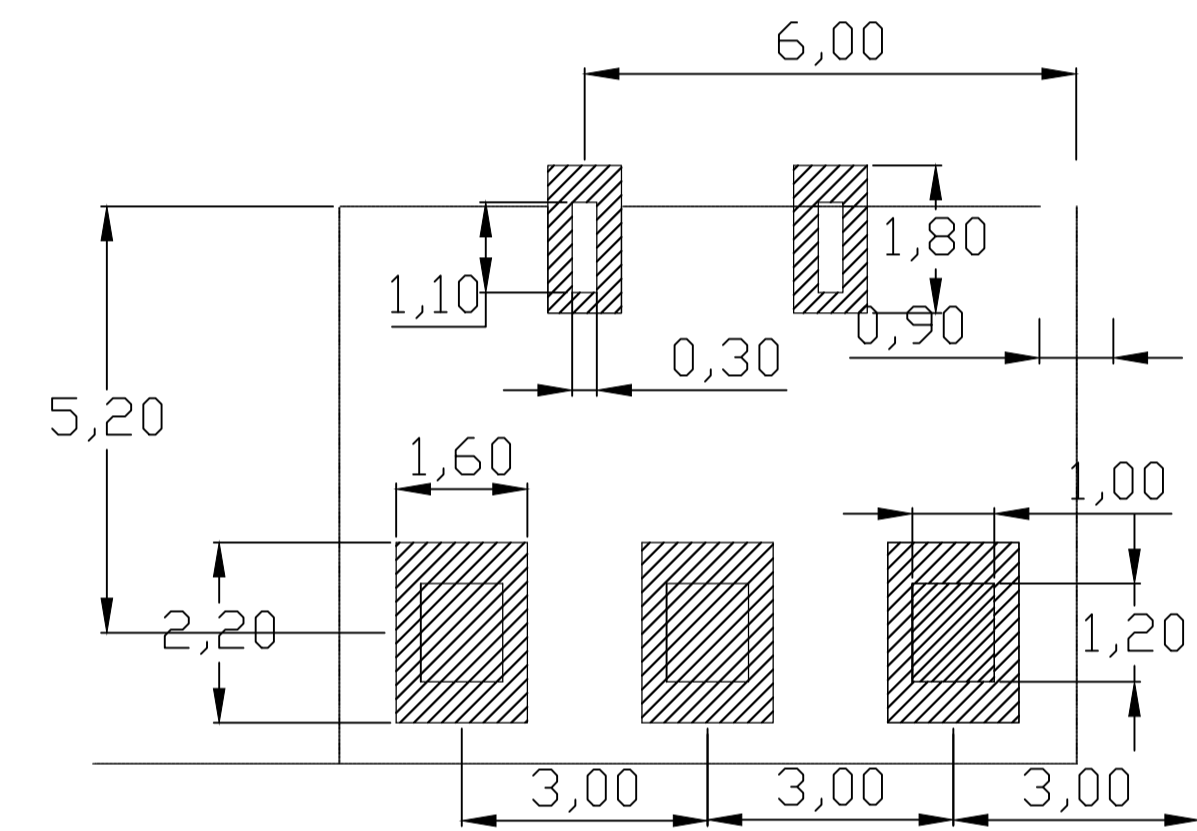
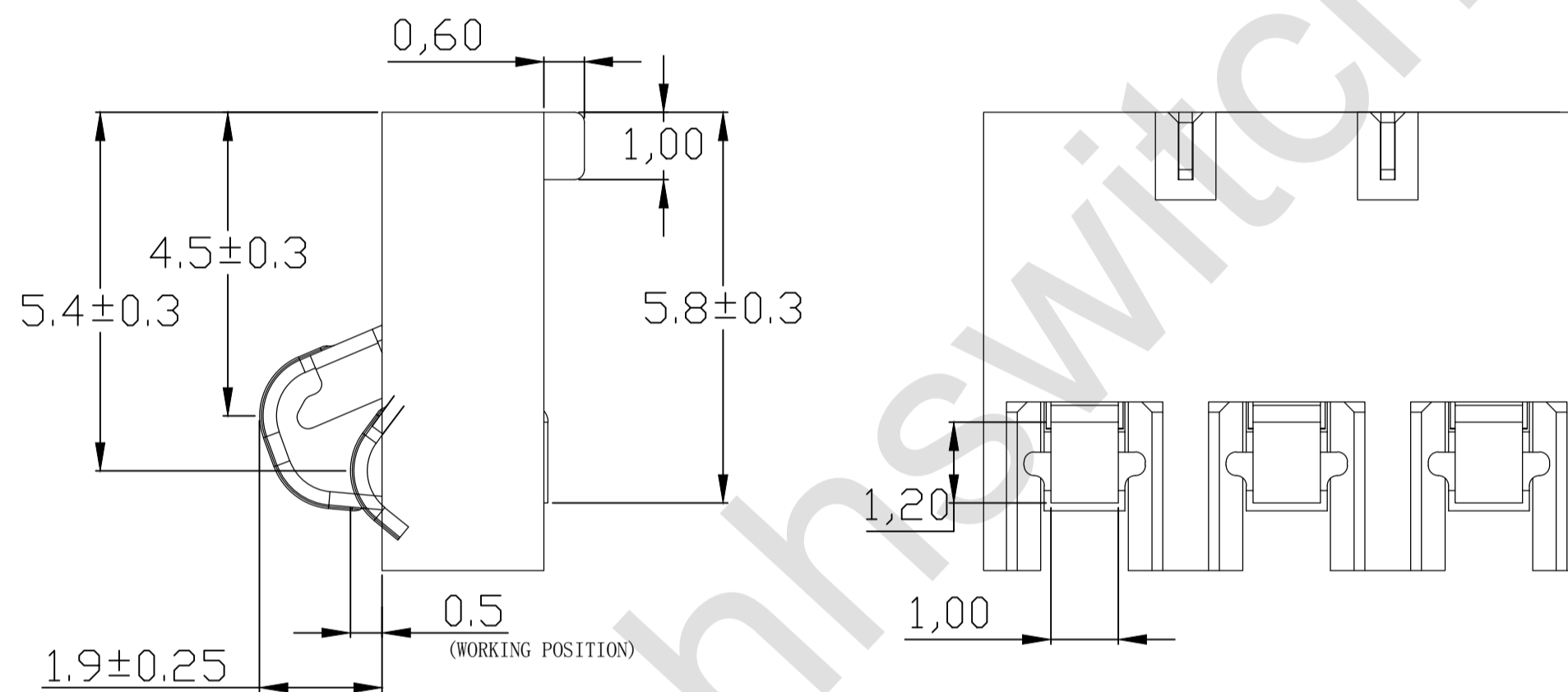
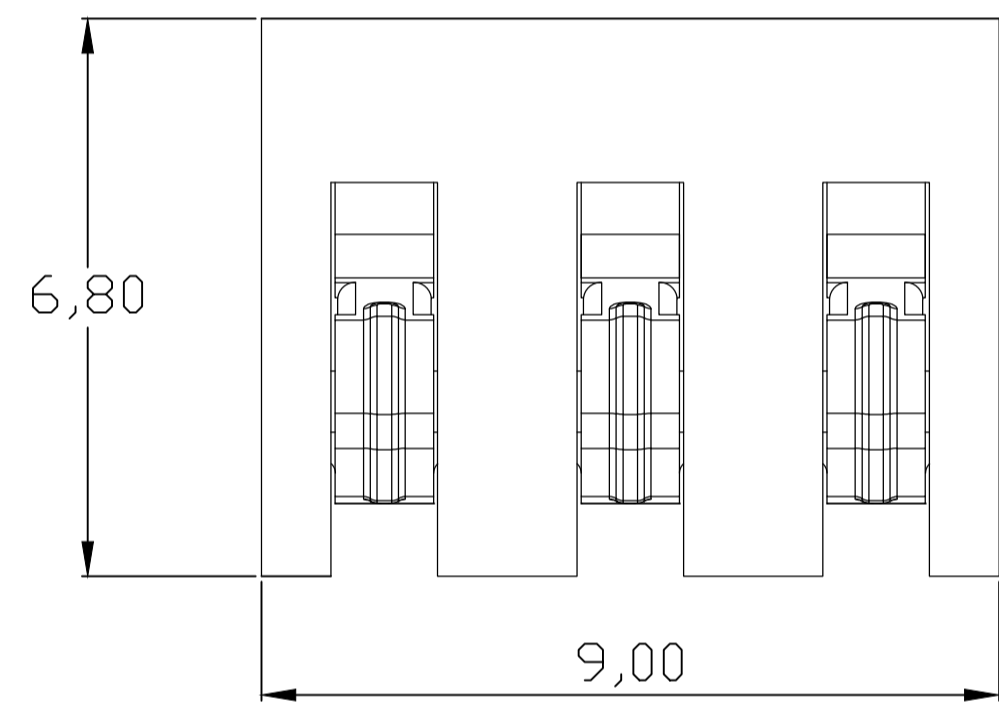
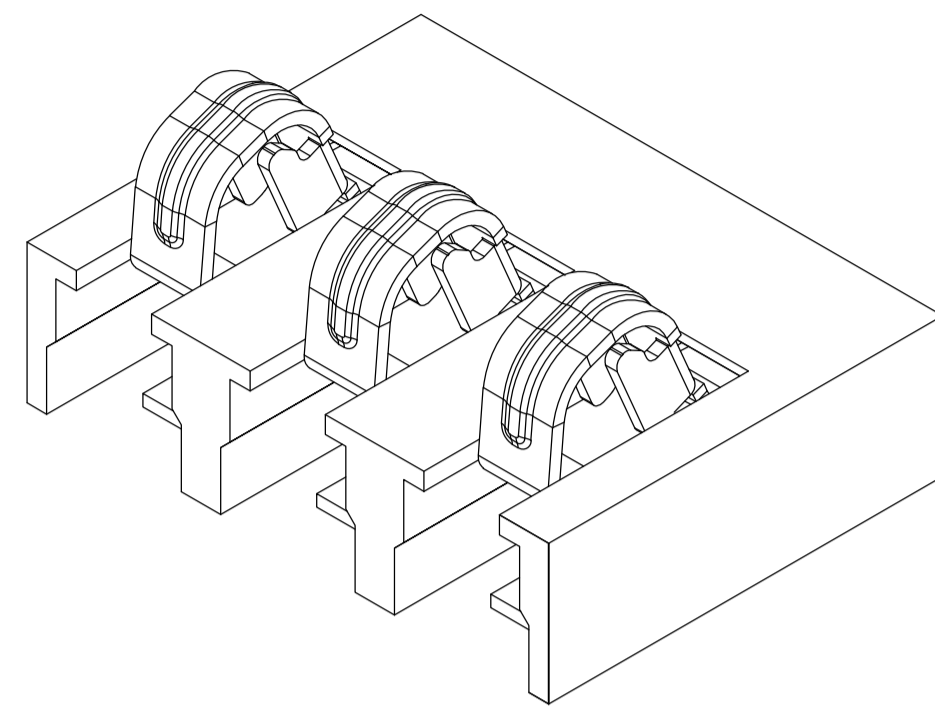
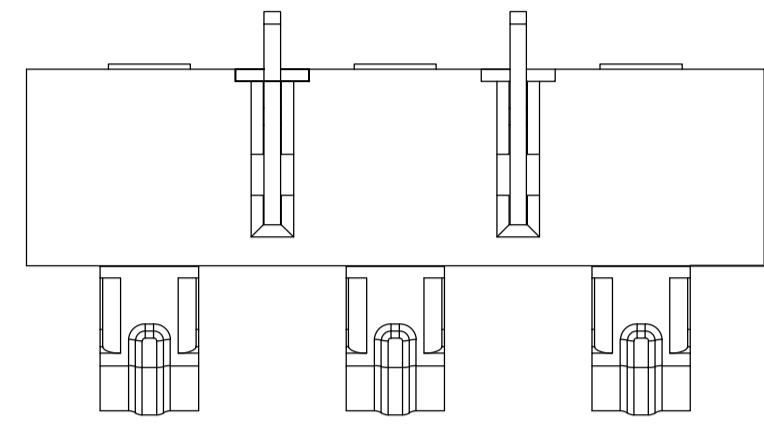

RECOMMENDED PCB LAYOUT
TOP VIEW (.XX±0.05)

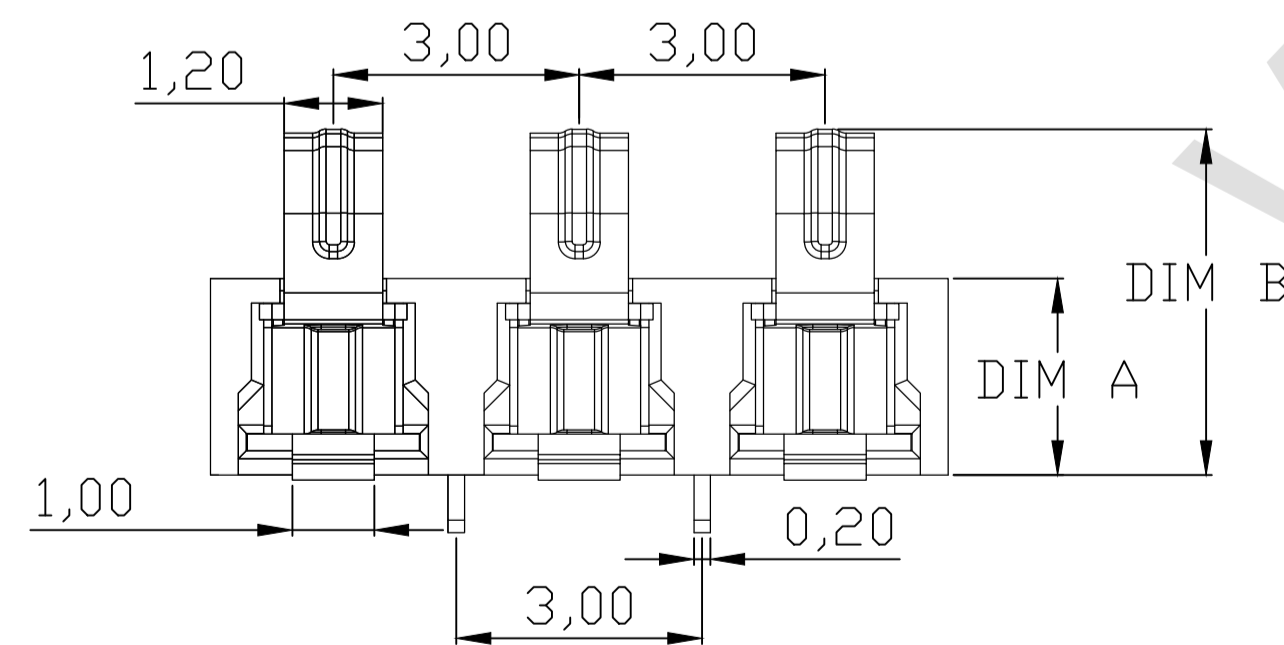

PART NO.	DIM A	DIM B
BHC060-3P240C06	2.4	4.30±0.25
BHC060-3P350C06	3.5	5.40±0.25

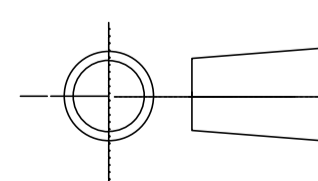

DESIGN	MISS ZENG	SC ALL			未注公差 T00LERANCE		品名: 电池连接器	
DRAWIGN	MISS LI	ANIT	MM		X. ±0.35	X.XX ±0.15		型号: BHC060-3P240C06
CHECK	Mr. ZENG	SIZE	A4: 210*297		X. X ±0.25	X. XXX ±0.05		
APPROVAL		VERSION	01					



东莞市航宏电子科技有限公司
Dongguan Hanghong Electronics Co., Ltd.

F E D C B A